

Features

- Latch-Up Performance Exceeds 800 mA
- Supply Voltage: 1.65V to 5.5V
- Low ON-State Resistance: maximum 3Ω at $V_s = 4.5V$
- Bandwidth: 300 MHz
- Fast switching times: $t_{ON} = 40\text{ ns}$, $t_{OFF} = 15\text{ ns}$
- Break-Before-Make Switching
- Operation Temperature Range: $-40^{\circ}C$ to $125^{\circ}C$

Applications

- Industry control systems
- Battery-powered systems
- Audio Signal Routing
- Portable Instruments and Mobile Device

Pin Configuration

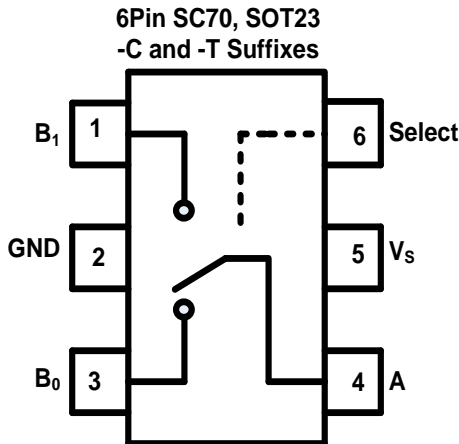

Description

TPW3157A is high performance Single Pole/Double Throw (SPDT) analog switches. The devices feature ultra low R_{ON} of 3Ω maximum at 4.5V V_{CC} and will operate over the wide V_{CC} range of 1.65V to 5.5V.

The TPW3157A features very low quiescent current even when the control voltage is lower than the V_{CC} supply. This feature services the portable applications very well allowing for the direct interface with processor general purpose I/Os.

Function Table

Input: Select Pin	Function
Low	B0 Connected to A
High	B1 Connected to A

Pin Description

Pin name	Pin No	Pin function
B1	1	Switch Port 1
GND	2	Ground
B0	3	Switch Port 0
A	4	Common switch port
V_{CC}	5	Power supply
Select	6	Select pin

Table of Contents

Features	1
Applications.....	1
Description.....	1
Function Table	1
Pin Description	1
Table of Contents	2
Revision History	3
Order Information.....	3
Absolute Maximum Ratings ^{Note 1}	4
ESD and Latch Up Rating	4
Thermal Information	4
Recommended Operating Conditions ^{Note 1}	4
Electrical Characteristics	5
Typical Performance Characteristics	9
Test Circuit and Waveforms	10
Tape and Reel Information	11
Package Outline Dimensions.....	12
SC70-5/6.....	12
SOT23-5/6	13

Revision History

Date	Revision	Notes
2018/4/5	Rev.Pre	Pre-Release Version
2018/10/1	Rev.0	Initial Release Version

Order Information

Order Number	Operating Temperature Range	Package	Marking Information	MSL	Transport Media, Quantity
TPW3157A-CR	-40 to 125°C	6-Pin SC70	315YW ^{Note 1}	3	Tape and Reel, 3000
TPW3157A-TR	-40 to 125°C	6-Pin SOT23	315YW ^{Note 1}	3	Tape and Reel, 3000

Note 1: "YW" is the date code means manufacture year and week as following.

The calendar year and the workweek coding scheme is as follows:

Year	Code	Year	Code	Workweek Code	Workweek Code	Workweek Code	Workweek Code	Workweek Code	
2010	A	2023	N	1	1	14	E	27	R
2011	B	2024	O	2	2	15	F	28	S
2012	C	2025	P	3	3	16	G	29	T
2013	D	2026	Q	4	4	17	H	30	U
2014	E	2027	R	5	5	18	I	31	V
2015	F	2028	S	6	6	19	J	32	W
2016	G	2029	T	7	7	20	K	33	X
2017	H	2030	U	8	8	21	L	34	Y
2018	I	2031	V	9	9	22	M	35	Z
2019	J	2032	W	10	A	23	N	36	a
2020	K	2033	X	11	B	24	O	37	b
2021	L	2034	Y	12	C	25	P	38	c
2022	M	2035	Z	13	D	26	Q	39	d
								40	e
								41	f
								42	g
								43	h
								44	i
								45	j
								46	k
								47	l
								48	m
								49	n
								50	o
								51	p
								52	q
								53	r

Absolute Maximum Ratings ^{Note 1}

Parameters	Rating
Supply Voltage, V_{CC}	-0.5V to 6V
Select Input Voltage	-0.5V to 6V
Select Input Diode Current	-50mA
Switch I/O Port Voltage	-0.5 to $V_{CC} + 0.5$
Switch I/O Port diode current	± 50 mA
Switch Current	120mA
Maximum Junction Temperature	150°C
Storage Temperature Range	-65 to 150°C
Lead Temperature (Soldering, 10 sec)	260°C

Note 1: Stresses beyond those listed under Absolute Maximum Ratings may cause permanent damage to the device. Exposure to any Absolute Maximum Rating condition for extended periods may affect device reliability and lifetime.

ESD and Latch Up Rating

Symbol	Parameter	Condition	Minimum Level	Unit
HBM	Human Body Model ESD	ANSI/ESDA/JEDEC JS-001	4	Kv
CDM	Charged Device Model ESD	ANSI/ESDA/JEDEC JS-002	2	Kv
LU	Latch Up	JESD 78, 25°C	800	mA
		JESD 78, 125°C	800	mA

Thermal Information

Package Type	θ_{JA}	θ_{JC}	Unit
6-Pin SC70	400		°C/W
6-Pin SOT	250	81	°C/W

Recommended Operating Conditions ^{Note 1}

Over operating temperature range

Parameters	Min	Max	Unit
Supply Voltage, V_{CC}	1.65	5.5	V
Select Input Voltage	0	V_{CC}	V
Input Transition Rise and Fall Rate		100	ns/V
Switch I/O Port Voltage	0V	V_{CC}	V
Operating Temperature Range	-40	125	°C

Note 1: Select input must be held HIGH or LOW and it must not float.

Electrical Characteristics

V_{CC} = 4.5 to 5.5V, unless otherwise noted.

Symbol	Parameter	Conditions	V _{CC} (V)	25°C	-40°C to 85°C	-40°C to 125°C	Limit	Unit
Power Supply								
I _{CC}	Quiescent Supply Current	V _{IN} = 0V or V _{CC}	5.5	0.3	0.5	1.5	Max	μA
Digital Input								
V _{IH}	Input Voltage High				2.4	2.4	Min	V
V _{IL}	Input Voltage Low				0.8	0.8	Max	V
I _{IN}	Control Input Leakage	V _{IN} = 0V or V _{CC}	5.5		±1	±1	Max	μA
Analog Switch								
R _{ON}		I _{OUT} = 100mA, B0 or B1 = 3.5V	4.5	1.5			Typ	Ω
R _{ON}		I _{OUT} = 100mA, B0 or B1 = 3.5V	4.5	2	3	3	Max	Ω
ΔR _{ON}	Maximum ON resistance	I _{OUT} = 100mA, B0 or B1 = 3.5V	4.5	0.3	0.4	0.4	Max	Ω
R _{FLAT(ON)}	On Resistance Flatness	I _{OUT} = 100mA, B0 or B1 = 0V, 1V, 2V	4.5	0.5	0.6	0.6	Max	Ω
I _{NO(OFF)} , I _{NC(OFF)}	Switch OFF Leakage Current on B0, B1	A = 1V, 4.5V, B0 or B1 = 4.5V, 1V	5.5	±10	±50	±100	Max	nA
I _{A(OFF)}	Switch OFF Leakage Current on A	A = 1V, 4.5V, B0 or B1 = 4.5V, 1V	5.5	±20	±100	±200	Max	nA
I _{A(ON)}	Switch ON Leakage Current on A	A = 1V, 4.5V, B0 or B1 = 1V, 4.5V or Floating	5.5	±20	±100	±200	Max	nA
Dynamic Characteristics								
t _{PHL} , t _{PLH}	Switch IN to OUT time	B0 or B1 = 3V, R _L = 50Ω, C _L = 35pF, Figure 3	4.5	5			Max	ns
t _{PZH} , t _{PZL}	Switch turn-on time	B0 or B1 = 3V, R _L = 50Ω, C _L = 35pF, Figure 3	4.5	40	50	50	Max	ns
t _{PHZ} , t _{PLZ}	Switch turn-off time	B0 or B1 = 3V, R _L = 50Ω, C _L = 35pF, Figure 3	4.5	20	25	25	Max	ns
t _B	Break before make time	B0 or B1 = 3V, R _L = 50Ω, C _L = 35pF, Figure 4	4.5	20	40	40	Typ	ns
Q	Charge Injection	C _L = 1.0nF, V _{GEN} = 0V, R _{GEN} = 0Ω, Figure 5	5	20			Typ	pC
	OFF-Isolation	f = 1MHz, R _L = 50Ω, Figure 6	5	-65			Typ	dB
	Crosstalk	f = 1MHz, R _L = 50Ω, Figure 7	5	-65			Typ	dB
BW	Bandwidth	R _L = 50Ω	5	100			Typ	MHz
THD	Total Harmonic Distortion	R _L = 600Ω, V _{IN} = 0.5V _{PP} , f = 20Hz to 20kHz	5	0.008			Typ	%
Capacitance								
C _{IN}	Select Input capacitance		5	5			Typ	pF
C _{OFF}	B-Port Off capacitance		5	12			Typ	pF
C _{ON}	ON Capacitance		5	40			Typ	pF

V_{CC} = 2.7 to 3.6V, unless otherwise noted.

Symbol	Parameter	Conditions	V _{CC} (V)	25°C	-40°C to 85°C	-40°C to 125°C	Limit	Unit
Power Supply								
I _{CC}	Quiescent Supply Current	V _{IN} = 0V or V _{CC}	3.6	0.3	0.5	1.5	Max	μA
Digital Input								
V _{IH}	Input Voltage High				1.65	1.65	Min	V
V _{IL}	Input Voltage Low				0.6	0.6	Max	V
I _{IN}	Control Input Leakage	V _{IN} = 0V or V _{CC}	3.6		±1	±1	Max	μA
Analog Switch								
R _{ON}		I _{OUT} = 100mA, B0 or B1 = 1.5V	2.7	3			Typ	Ω
R _{ON}		I _{OUT} = 100mA, B0 or B1 = 1.5V	2.7	5	8	8	Max	Ω
ΔR _{ON}	Maximum ON resistance	I _{OUT} = 100mA, B0 or B1 = 1.5V	2.7	0.5	0.6	0.6	Max	Ω
R _{FLAT(ON)}	On Resistance Flatness	I _{OUT} = 100mA, B0 or B1 = 0V, 0.75V, 1.5V	2.7	1.5	2	2	Max	Ω
I _{NO(OFF)} , I _{NC(OFF)}	Switch OFF Leakage Current on B0, B1	A = 1V, 4.5V, B0 or B1 = 4.5V, 1V	3.6	±10	±50	±100	Max	nA
I _{A(OFF)}	Switch OFF Leakage Current on A	A = 1V, 4.5V, B0 or B1 = 4.5V, 1V	3.6	±20	±100	±200	Max	nA
I _{A(ON)}	Switch ON Leakage Current on A	A = 1V, 4.5V, B0 or B1 = 1V, 4.5V or Floating	3.6	±20	±100	±200	Max	nA
Dynamic Characteristics								
t _{PHL} , t _{PLH}	Switch IN to OUT time	B0 or B1 = 1.5V, R _L = 50Ω, C _L = 35pF, Figure 3	2.7	10			Typ	ns
t _{PZH} , t _{PZL}	Switch turn-on time	B0 or B1 = 1.5V, R _L = 50Ω, C _L = 35pF, Figure 3	2.7	70	80	80	Max	ns
t _{PHZ} , t _{PLZ}	Switch turn-off time	B0 or B1 = 1.5V, R _L = 50Ω, C _L = 35pF, Figure 3	2.7	25	40	40	Max	ns
t _B	Break before make time	B0 or B1 = 1.5V, R _L = 50Ω, C _L = 35pF, Figure 4	2.7	20			Typ	ns
Q	Charge Injection	C _L = 1.0nF, V _{GEN} = 0V, R _{GEN} = 0Ω, Figure 5	3	20			Typ	pC
	OFF-Isolation	f = 1MHz, R _L = 50Ω, Figure 6	3	-65			Typ	dB
	Crosstalk	f = 1MHz, R _L = 50Ω, Figure 7	3	-65			Typ	dB
BW	Bandwidth	R _L = 50Ω	3	100			Typ	MHz
THD	Total Harmonic Distortion	R _L = 600Ω, V _{IN} = 0.5V _{PP} , f = 20Hz to 20kHz	3	0.01			Typ	%

V_{CC} = 1.65 to 1.95V, unless otherwise noted.

Symbol	Parameter	Conditions	V _{CC} (V)	25°C	-40°C to 85°C	-40°C to 125°C	Limit	Unit
Power Supply								
I _{CC}	Quiescent Supply Current	V _{IN} = 0V or V _{CC}	1.95	0.3	0.5	1.5	Max	μA
Digital Input								
V _{IH}	Input Voltage High				1.4	1.4	Min	V
V _{IL}	Input Voltage Low				0.4	0.4	Max	V
I _{IN}	Control Input Leakage	V _{IN} = 0V or V _{CC}	1.95		±1	±1	Max	μA
Analog Switch								
R _{ON}		I _{OUT} = 10mA, B0 or B1 = 0.9V	1.65	15			Typ	Ω
R _{ON}		I _{OUT} = 10mA, B0 or B1 = 0.9V	1.65	20	25	25	Max	Ω
ΔR _{ON}	Maximum ON resistance	I _{OUT} = 10mA, B0 or B1 = 0.9V	1.65	3	5	5	Max	Ω
I _{NO(OFF)} , I _{NC(OFF)}	Switch OFF Leakage Current on B0, B1	A = 0V, 1.95V, B0 or B1 = 1.95V, 0V	1.95	±10	±50	±100	Max	nA
I _{A(OFF)}	Switch OFF Leakage Current on A	A = 0V, 1.95V, B0 or B1 = 1.95V, 0V	1.95	±20	±100	±200	Max	nA
I _{A(ON)}	Switch ON Leakage Current on A	A = 0V, 1.95V, B0 or B1 = 0V, 1.95V or Floating	1.95	±20	±100	±200	Max	nA
Dynamic Characteristics								
t _{PHL} , t _{PLH}	Switch IN to OUT time	B0 or B1 = 1.0V, R _L = 50Ω, C _L = 35pF, Figure 3	1.65	10			Typ	ns
t _{PZH} , t _{PZL}	Switch turn-on time	B0 or B1 = 1.0V, R _L = 50Ω, C _L = 35pF, Figure 3	1.65	80	90	90	Max	ns
t _{PHZ} , t _{PLZ}	Switch turn-off time	B0 or B1 = 1.0V, R _L = 50Ω, C _L = 35pF, Figure 3	1.65	50	70	70	Max	ns
t _B	Break before make time	B0 or B1 = 1.0V, R _L = 50Ω, C _L = 35pF, Figure 4	1.65	20			Max	ns
Q	Charge Injection	C _L = 1.0nF, V _{GEN} = 0V, R _{GEN} = 0Ω, Figure 5	1.8	20			Typ	pC
	OFF-Isolation	f = 1MHz, R _L = 50Ω, Figure 6	1.8	-65			Typ	dB
	Crosstalk	f = 1MHz, R _L = 50Ω, Figure 7	1.8	-65			Typ	dB
BW	Bandwidth	R _L = 50Ω	1.8	100			Typ	MHz
THD	Total Harmonic Distortion	R _L = 600Ω, V _{IN} = 0.5V _{PP} , f = 20Hz to 20kHz	1.8	0.01			Typ	%

T_A = 0°C to 50°C, unless otherwise noted.

Symbol	Parameter	Conditions	V _{CC} (V)	Spec	Limit	Unit
I _{NO(OFF)} , I _{NC(OFF)}	Switch OFF Leakage Current on B0, B1	A = 1V, 4.5V, B0 or B1 = 4.5V, 1V	3.6	±10	Max	nA
I _{A(OFF)}	Switch OFF Leakage Current on A	A = 1V, 4.5V, B0 or B1 = 4.5V, 1V	3.6	±20	Max	nA
I _{A(ON)}	Switch ON Leakage Current on A	A = 1V, 4.5V, B0 or B1 = 1V, 4.5V or Floating	3.6	±20	Max	nA
I _{NO(OFF)} , I _{NC(OFF)}	Switch OFF Leakage Current on B0, B1	A = 1V, 4.5V, B0 or B1 = 4.5V, 1V	5.5	±10	Max	nA
I _{A(OFF)}	Switch OFF Leakage Current on A	A = 1V, 4.5V, B0 or B1 = 4.5V, 1V	5.5	±20	Max	nA
I _{A(ON)}	Switch ON Leakage Current on A	A = 1V, 4.5V, B0 or B1 = 1V, 4.5V or Floating	5.5	±20	Max	nA

Typical Performance Characteristics

V_{CC} = 5V, unless otherwise specified.

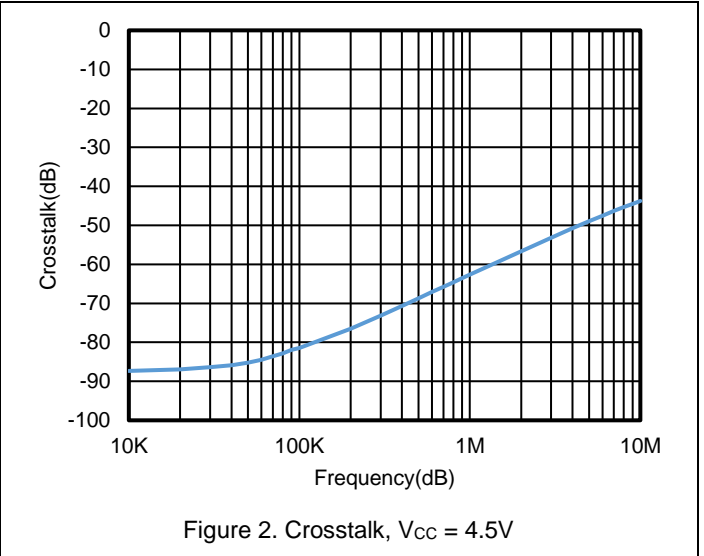
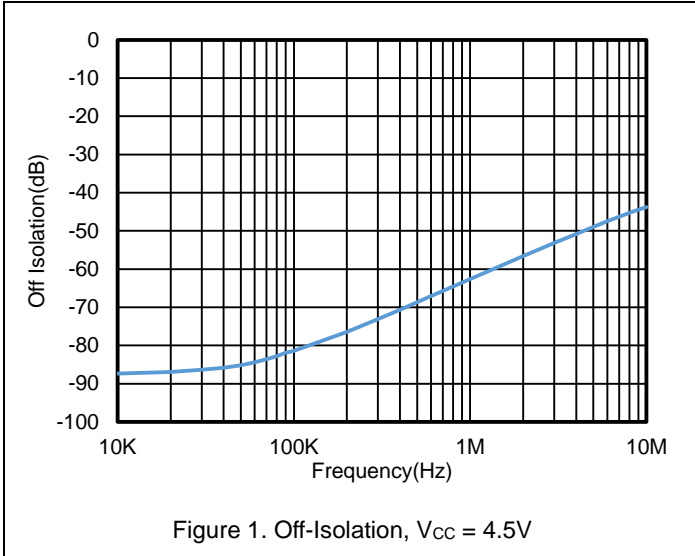

Test Circuit and Waveforms

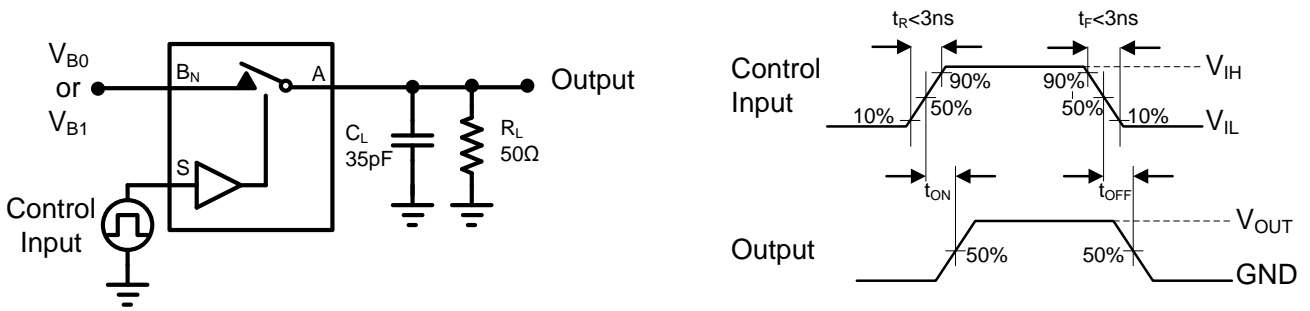

Figure 3 AC Test Circuit and Test Waveforms

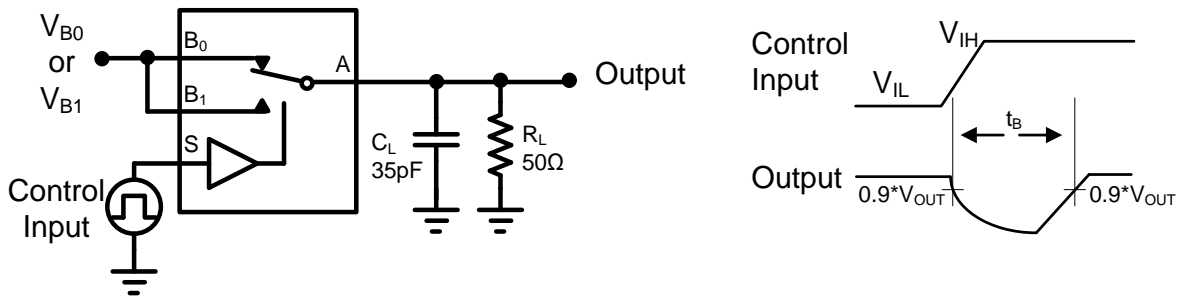

Figure 4 Switch Break Time

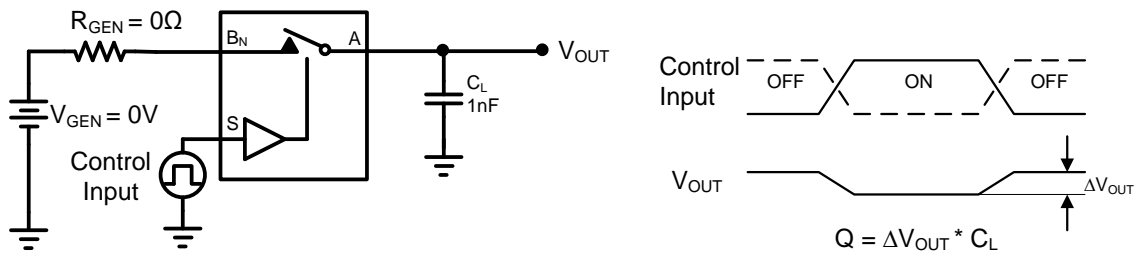

Figure 5 Charge Injection

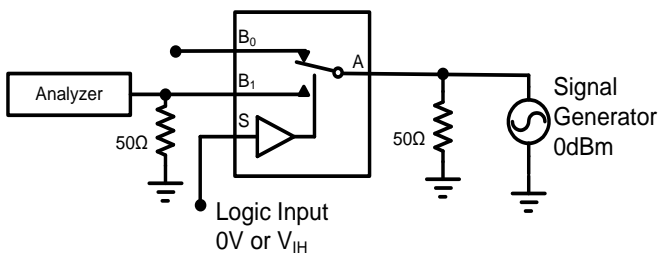

Figure 6 Off Isolation

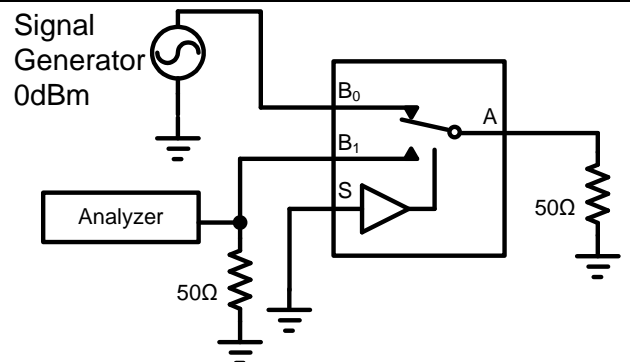
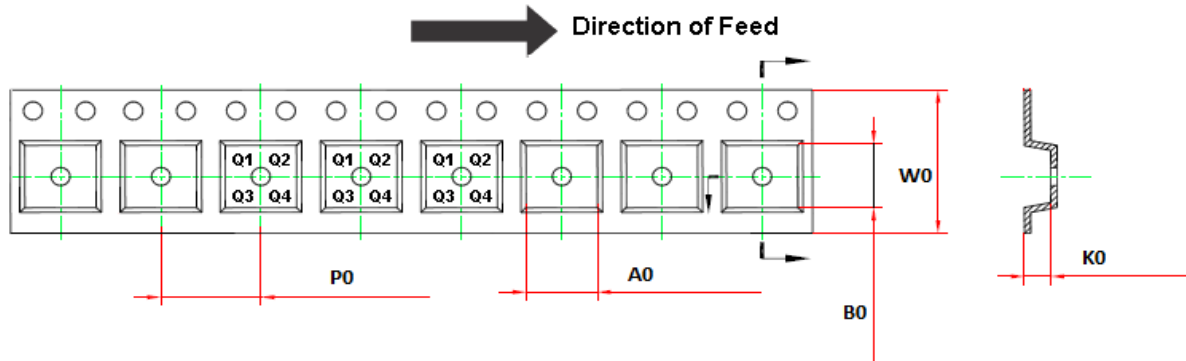
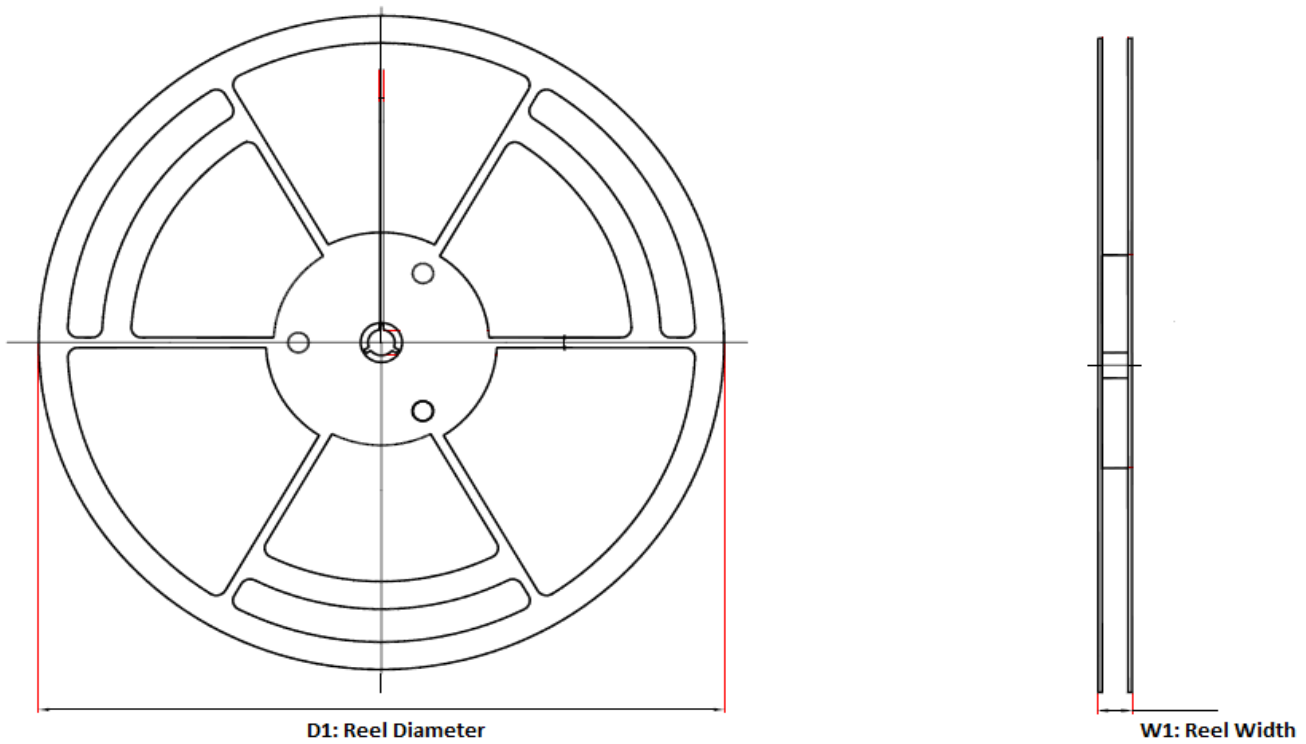

Figure 7 Crosstalk

Tape and Reel Information



Order Number	Package	D1	W1	A0	B0	K0	P0	W0	Pin1 Quadrant
TPW3157A-CR	6-Pin SC70	178±1	12.3±1	2.4±0.1	2.5±0.1	1.2±0.1	4.0±0.1	8.0±0.1	Q3
TPW3157A-TR	6-Pin SOT23	178±1	12.3±1	3.23±0.1	3.17±0.1	1.37±0.1	4.0±0.1	8.0±0.1	Q3

Package Outline Dimensions

SC70-5/6

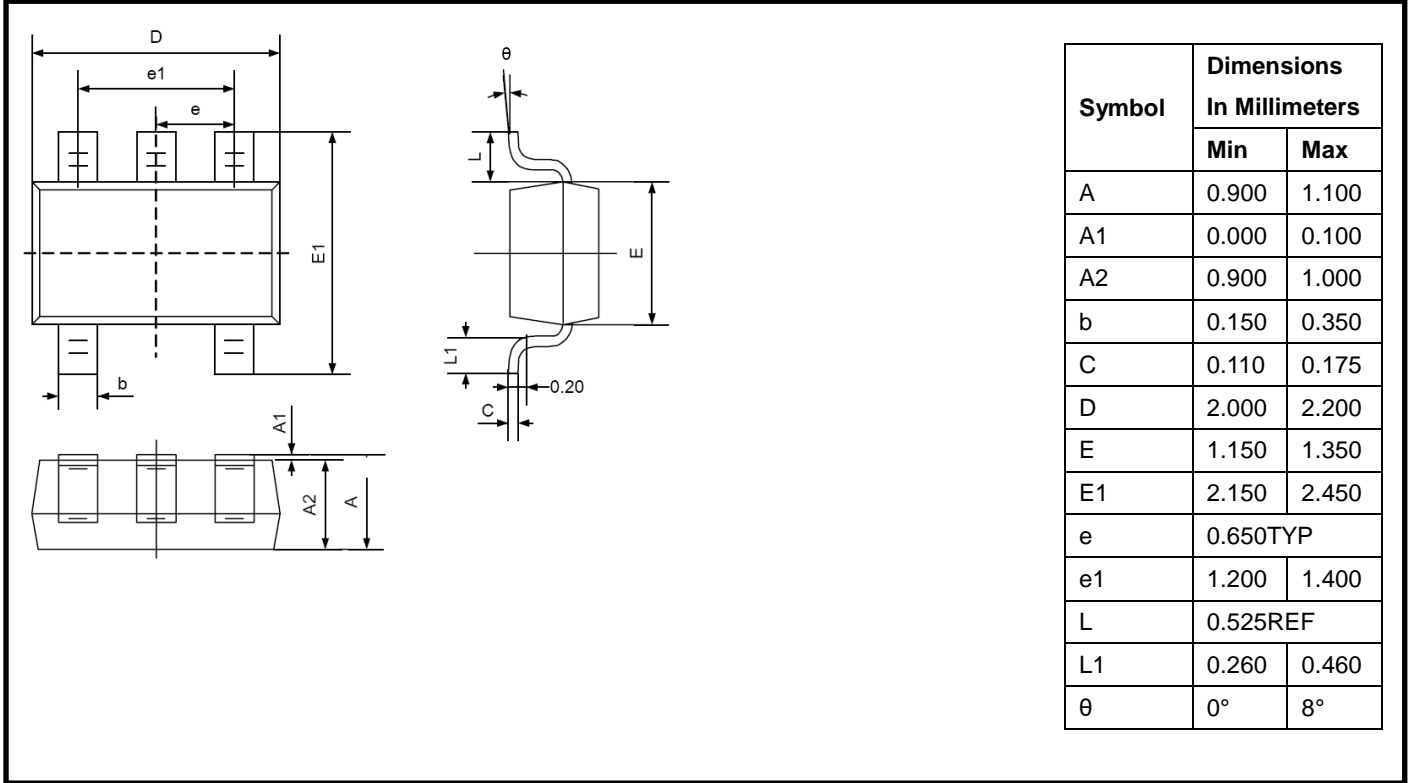

SOT23-5/6

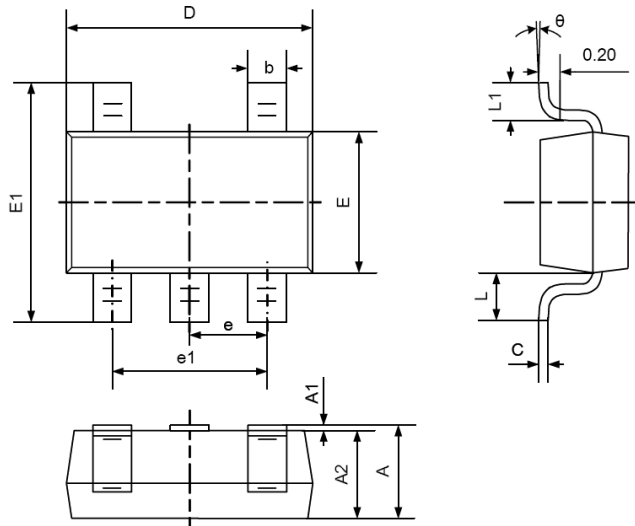

Symbol	Dimensions In Millimeters	
	Min	Max
A	1.050	1.250
A1	0.000	0.100
A2	1.000	1.150
b	0.300	0.500
C	0.100	0.200
D	2.820	3.020
E	1.500	1.700
E1	2.600	3.000
e	0.950TYP	
e1	1.800	2.000
L	0.600REF	
L1	0.300	0.600
θ	0°	8°

 ***3PEAK and the 3PEAK logo are registered trademarks of 3PEAK INCORPORATED. All other trademarks are the property of their respective owners.***
