

Features

- Analog Switch Voltage: 3.3V, 5V, 10V, $\pm 5V$
- Low ON-State Resistance:
 - typical 50 Ω at $V_s = \pm 4.5V$ or 9V
 - typical 60 Ω at $V_s = 4.5V$
 - typical 300 Ω at $V_s = 3V$
- Bandwidth: 200 MHz
- Fast switching times: $t_{ON} = 60ns$, $t_{OFF} = 50ns$
- Break-Before-Make Switching
- Operation Temperature Range: $-40^{\circ}C$ to $125^{\circ}C$

Applications

- Industry control systems
- Battery-powered systems
- Audio Signal Routing
- Instrumentation

Description

The TPW4051 is a single-pole octal-throw analog switch (SP8T) suitable for use in analog or digital 8:1 multiplexer/demultiplexer applications. The switch features three digital select inputs (S0, S1 and S2), eight independent inputs/outputs (An), a common input/output (A) and a digital enable input (/E). When /E is HIGH, the switches are turned off.

The device is designed on an enhanced process that provides lower power dissipation yet gives high switching speeds. These devices can operate equally well as either multiplexers or demultiplexers and have an input range that extends to the supplies. All channels exhibit break-before-make switching action, preventing momentary shorting when switching channels.

Switch Selection Guide

Product	Switch Configuration	Supply Voltage(V)	Ron(OHM)	Bandwidth(MHz)	Package
TPW4051	8:1	12	50	200	SOIC-16, TSSOP-16, QFN-16
TPW4052	(4:1)*2	12	50	200	SOIC-16, TSSOP-16
TPW4053	(2:1)*3	12	50	200	SOIC-16, TSSOP-16
TPW3111	1:1	5.5	1	100	SC70-5
TPW3115	1:1	5.5	5	250	SC70-5, SOT23-5
TPW4157	2:1	5.5	1	100	SC70-6
TPW3157A	2:1	5.5	2	100	SC70-6
TPW3221	(2:1)*2	5.5	1	100	MSOP-10
TPW3223	(2:1)*2	5.5	1	100	QFN-10, 1.4*1.8mm

Table of Contents

Features	1
Applications.....	1
Description.....	1
Switch Selection Guide	1
Table of Contents	2
Revision History	3
Order Information.....	3
Pin Configuration, Description and Functional Table ^{Note 1}	4
TPW4051	4
Absolute Maximum Ratings ^{Note 1}	6
ESD Rating.....	6
Thermal Information	6
Recommended Operating Conditions ^{Note 1}	6
Electrical Characteristics	7
Single Supply, $V_{CC} = 4.5$ to $5.5V$, $V_{EE} = 0V$, $GND = 0V$, unless otherwise noted.....	7
Single Supply, $V_{CC} = 3$ to $3.6V$, $V_{EE} = 0V$, $GND = 0V$, unless otherwise noted.	8
Single Supply, $V_{CC} = 9V$ to $11V$, $V_{EE} = 0V$, $GND = 0V$, unless otherwise noted.	9
Dual Supply, $V_{CC} = 4.5$ to $5.5V$, $V_{EE} = -4.5$ to $5.5V$, $GND = 0V$, unless otherwise noted.	10
Typical Performance Characteristics	11
Test Circuit and Waveforms	12
Application Information.....	13
Tape and Reel Information	14
Package Outline Dimensions.....	15
SOIC-16	15
TSSOP-16.....	15
QFN-16	16

Revision History

Date	Revision	Notes
2018/8/8	Rev.Pre	Pre-Release Version
2019/3/4	Rev.0	Initial Version
2019/10/2	Rev.0.01	HBM: 2KV -> 1KV
2019/12/25	Rev.0.02	Correct test conditions of RON and switch leakage to follow the product test(Product test is not changed): all of "0V" -> "VEE"; On Resistance Match between Channels at 3 to 3.6V Vcc: -> remove; On Resistance Match between Channels at 9 to 11V Vcc: VIS = 3.5V -> VIS = 1V; On Resistance Match between Channels at 4.5 to 5.5V Vcc, Vee = -4.5V to 5.5V: VIS = 3.5V -> VIS = -3.5V
2020/1/14	Rev.0.03	Correct the "P0" information of TR in Tape and Reel Information

Order Information

Order Number	Operating Temperature Range	Package	Marking Information	MSL	Transport Media, Quantity
TPW4051-SR	-40 to 125°C	16-Pin SOIC	W4051	3	Tape and Reel, 2500
TPW4051-TR	-40 to 125°C	16-Pin TSSOP	W4051	3	Tape and Reel, 3000
TPW4051-QF4R	-40 to 125°C	16-Pin QFN 3*3	W4051	3	Tape and Reel, 3000

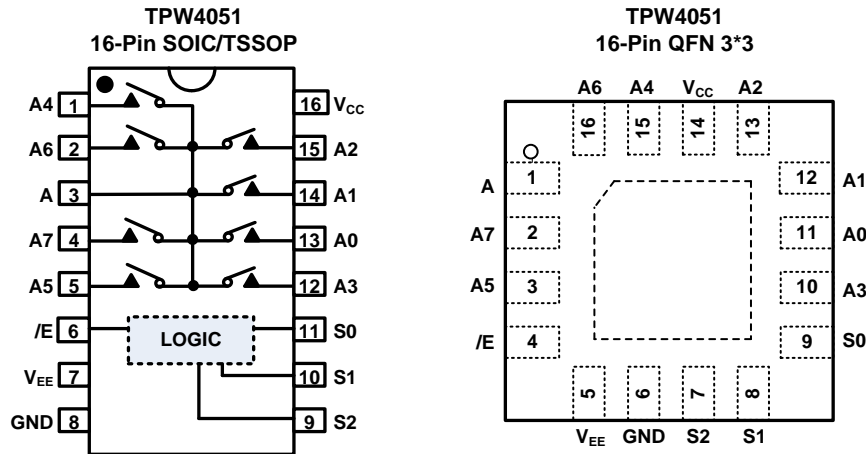
Pin Configuration, Description and Functional Table Note 1
TPW4051

Pin Description of SOIC and TSSOP

Pin No.	Pin Name	Input / Output	Description	Pin No.	Pin Name	Input / Output	Description
1	A4	Input / Output	Channel 4 input or output	9	S2	Input	Control Input
2	A6	Input / Output	Channel 6 input or output	10	S1	Input	Control Input
3	A	Input / Output	Common input or output	11	S0	Input	Control Input
4	A7	Input / Output	Channel 7 input or output	12	A3	Input / Output	Channel 3 input or output
5	A5	Input / Output	Channel 5 input or output	13	A0	Input / Output	Channel 0 input or output
6	/E	Input	Enable switches, active low	14	A1	Input / Output	Channel 1 input or output
7	V _{EE}		Negative Power Input	15	A2	Input / Output	Channel 2 input or output
8	GND		Ground	16	V _{CC}		Positive Power Input

Pin Description of QFN

Pin No.	Pin Name	Input / Output	Description	Pin No.	Pin Name	Input / Output	Description
1	A	Input / Output	Common input or output	9	S0	Input	Control Input
2	A7	Input / Output	Channel 7 input or output	10	A3	Input / Output	Channel 3 input or output
3	A5	Input / Output	Channel 5 input or output	11	A0	Input / Output	Channel 0 input or output
4	/E	Input	Enable switches, active low	12	A1	Input / Output	Channel 1 input or output
5	V _{EE}		Negative Power Input	13	A2	Input / Output	Channel 2 input or output
6	GND		Ground	14	V _{CC}		Positive Power Input
7	S2	Input	Control Input	15	A4	Input / Output	Channel 4 input or output
8	S1	Input	Control Input	16	A6	Input / Output	Channel 6 input or output

Functional Table

/E, Enable	S2	S1	S0	ON Channel
L	L	L	L	A0
L	L	L	H	A1
L	L	H	L	A2

12V General Purpose Analog Switch

L	L	H	H	A3
L	H	L	L	A4
L	H	L	H	A5
L	H	H	L	A6
L	H	H	H	A7
H	X	X	X	None

X = Don't care

Absolute Maximum Ratings ^{Note 1}

Parameters	Rating
Supply Voltage, $V_{CC} - V_{EE}$	-0.5V to 13V
Supply Voltage, $V_{CC} - GND$	-0.5V to 13V
Supply Voltage, $V_{EE} - GND$	-6.5V to 0.5V
Analog Switch Voltage	$V_{EE} - 0.5V$ to $V_{CC} + 0.5V$
Analog Switch Current	$\pm 25mA$
Analog Switch Diode Current	$\pm 20mA$
Digital Input Voltage, /E, S2, S1, S0	GND to $V_{CC} + 0.5V$
Digital Input Diode Current	$\pm 20mA$
Maximum Junction Temperature	150°C
Storage Temperature Range	-65 to 150°C
Lead Temperature (Soldering, 10 sec)	260°C

Note 1: Stresses beyond those listed under Absolute Maximum Ratings may cause permanent damage to the device. Exposure to any Absolute Maximum Rating condition for extended periods may affect device reliability and lifetime.

ESD Rating

Symbol	Parameter	Condition	Minimum Level	Unit
HBM	Human Body Model ESD	ANSI/ESDA/JEDEC JS-001	1	kV
CDM	Charged Device Model ESD	ANSI/ESDA/JEDEC JS-002	1	kV

Thermal Information

Package Type	θ_{JA}	θ_{JC}	Unit
16-Pin SOIC	100	50	°C/W
16-Pin TSSOP	150	60	°C/W

Recommended Operating Conditions ^{Note 1}

Over operating temperature range

Parameters	Min	Max	Unit
Supply Voltage, $V_{CC} - V_{EE}$	3	12	V
Supply Voltage, $V_{CC} - GND$ ^{Note2}	3	12	V
Supply Voltage, $V_{EE} - GND$ ^{Note2}	-6	0	V
Select Input Voltage	0	V_{CC}	V
Input Transition Rise and Fall Rate		100	ns/V
Switch I/O Port Voltage	V_{EE}	V_{CC}	V
Operating Temperature Range	-40	125	°C

Note 1: Select input must be held HIGH or LOW and it must not float.

Note 2: The voltage of V_{CC} , V_{EE} need be in the range of $V_{CC}-V_{EE}$

Electrical Characteristics

Single Supply, $V_{CC} = 4.5$ to $5.5V$, $V_{EE} = 0V$, $GND = 0V$, unless otherwise noted.

Symbol	Parameter	Conditions	V_{CC} (V)	25°C	-40°C to 85°C	-40°C to 125°C	Limit	Unit
Power Supply								
I_{CC}	Quiescent Supply Current	$V_{IN} = V_{EE}$ or V_{CC}	5.5	4	6	8	Max	μA
Digital Input								
V_{IH}	Input Voltage High				2.0	2.0	Min	V
V_{IL}	Input Voltage Low				0.8	0.8	Max	V
I_{IN}	Control Input Leakage	$V_{IN} = 0V$ or V_{CC}	5.5	± 0.4	± 1	± 1	Max	μA
Analog Switch								
R_{ON}		$I_{OUT} = 1mA$, $V_{IS} = V_{EE}$ or V_{CC}	4.5	60			Typ	Ω
R_{ON}		$I_{OUT} = 1mA$, $V_{IS} = V_{EE}$ or V_{CC}	4.5	100	130	150	Max	Ω
ΔR_{ON}	On Resistance Match between Channels	$I_{OUT} = 1mA$, $V_{IS} = 2.5V$	4.5	20	30	35	Max	Ω
$R_{FLAT(ON)}$	On Resistance Flatness	$I_{OUT} = 1mA$	4.5	60	80	80	Max	Ω
$I_{CH(OFF)}$	Switch OFF Leakage Current on Channel	$V_{IS} = V_{EE}$, $V_{OS} = V_{CC}$; or $V_{IS} = V_{CC}$, $V_{OS} = V_{EE}$	5.5	± 0.4	± 1	± 1	Max	μA
$I_{COM(OFF)}$	Switch OFF Leakage Current on Common	$V_{IS} = V_{EE}$, $V_{OS} = V_{CC}$; or $V_{IS} = V_{CC}$, $V_{OS} = V_{EE}$	5.5	± 0.4	± 4	± 4	Max	μA
$I_{(ON)}$	Switch ON Leakage Current	$V_{IS} = V_{EE}$ or V_{CC}	5.5	± 0.4	± 4	± 4	Max	μA
Dynamic Characteristics								
t_{PHL} , t_{PLH}	Switch IN to OUT time	$C_L = 50pF$	4.5	5			Typ	ns
t_{ON}	Switch turn-on time	$C_L = 50pF$	4.5	60			Max	ns
t_{OFF}	Switch turn-off time	$C_L = 50pF$	4.5	50			Max	ns
	OFF-Isolation	$f = 1MHz$, $R_L = 50\Omega$, $C_L = 10pF$	5	-70			Typ	dB
	Crosstalk in channel	$f = 1MHz$, $R_L = 50\Omega$, $C_L = 10pF$	5	-70			Typ	dB
	Crosstalk in control	Between control and any switch; $R_L = 600\Omega$; $f = 1 MHz$; E or Sn square wave between V_{CC} and GND	5	110			Typ	mV
BW	Bandwidth	$R_L = 50\Omega$	5	200			Typ	MHz
THD	Total Harmonic Distortion	$R_L = 10k\Omega$, $f = 1kHz$	5	0.05			Typ	%
Capacitance								
C_{IN}	Switch Input Capacitance		5	5			Typ	pF
C_{COM}	Common Output Capacitance		5	25			Typ	pF
C_{PD}	Power Dissipation Capacitance		5	50			Typ	pF

Single Supply, $V_{CC} = 3$ to $3.6V$, $V_{EE} = 0V$, $GND = 0V$, unless otherwise noted.

Symbol	Parameter	Conditions	V_{CC} (V)	25°C	-40°C to 85°C	-40°C to 125°C	Limit	Unit
Power Supply								
I_{CC}	Quiescent Supply Current	$V_{IN} = V_{EE}$ or V_{CC}	3.6	4	6	8	Max	μA
Digital Input								
V_{IH}	Input Voltage High				2.0	2.0	Min	V
V_{IL}	Input Voltage Low				0.8	0.8	Max	V
I_{IN}	Control Input Leakage	$V_{IN} = 0V$ or V_{CC}	3.6		± 1	± 1	Max	μA
Analog Switch								
R_{ON}		$I_{OUT} = 1mA$, $V_{IS} = V_{EE}$ or V_{CC}	3	300			Typ	Ω
$R_{FLAT(ON)}$	On Resistance Flatness	$I_{OUT} = 1mA$	3	100			Typ	Ω
$I_{CH(OFF)}$	Switch OFF Leakage Current on Channel	$V_{IS} = V_{EE}$, $V_{OS} = V_{CC}$; or $V_{IS} = V_{CC}$, $V_{OS} = V_{EE}$	3.6	± 0.4	± 1	± 1	Max	μA
$I_{COM(OFF)}$	Switch OFF Leakage Current on Common	$V_{IS} = V_{EE}$, $V_{OS} = V_{CC}$; or $V_{IS} = V_{CC}$, $V_{OS} = V_{EE}$	3.6	± 0.4	± 4	± 4	Max	μA
$I_{(ON)}$	Switch ON Leakage Current	$V_{IS} = V_{EE}$ or V_{CC}	3.6	± 0.4	± 4	± 4	Max	μA
Dynamic Characteristics								
t_{PHL} , t_{PLH}	Switch IN to OUT time	$C_L = 50pF$	3	5			Typ	ns
t_{ON}	Switch turn-on time	$C_L = 50pF$	3	70			Typ	ns
t_{OFF}	Switch turn-off time	$C_L = 50pF$	3	60			Typ	ns
	OFF-Isolation	$f = 1MHz$, $R_L = 50\Omega$, $C_L = 10pF$	3.3	-70			Typ	dB
	Crosstalk	$f = 1MHz$, $R_L = 50\Omega$, $C_L = 10pF$	3.3	-70			Typ	dB
	Crosstalk in control	Between control and any switch; $R_L = 600\Omega$; $f = 1MHz$; E or Sn square wave between V_{CC} and GND	3.3	110			Typ	mV
BW	Bandwidth	$R_L = 50\Omega$	3.3	100			Typ	MHz
THD	Total Harmonic Distortion	$R_L = 10k\Omega$, $f = 1kHz$	3.3	0.2			Typ	%
Capacitance								
C_{IN}	Switch Input Capacitance		3.3	5			Typ	pF
C_{COM}	Common Output Capacitance		3.3	25			Typ	pF
C_{PD}	Power Dissipation Capacitance		3.3	50			Typ	pF

Single Supply, $V_{CC} = 9V$ to $11V$, $V_{EE} = 0V$, $GND = 0V$, unless otherwise noted.

Symbol	Parameter	Conditions	V_{CC} (V)	25°C	-40°C to 85°C	-40°C to 125°C	Limit	Unit
Power Supply								
I_{CC}	Quiescent Supply Current	$V_{IN} = V_{EE}$ or V_{CC}	9	8	12	16	Max	μA
Digital Input								
V_{IH}	Input Voltage High				2.4	2.4	Min	V
V_{IL}	Input Voltage Low				0.8	0.8	Max	V
I_{IN}	Control Input Leakage	$V_{IN} = 0V$ or V_{CC}	11	± 0.4	± 1	± 1	Max	μA
Analog Switch								
R_{ON}		$I_{OUT} = 1mA$, $V_{IS} = V_{EE}$ or V_{CC}	9	50			Typ	Ω
R_{ON}		$I_{OUT} = 1mA$, $V_{IS} = V_{EE}$ or V_{CC}	9	80	95	105	Max	Ω
ΔR_{ON}	On Resistance Match between Channels	$I_{OUT} = 1mA$, $V_{IS} = 1V$	9	15	25	30	Max	Ω
$R_{FLAT(ON)}$	On Resistance Flatness	$I_{OUT} = 1mA$	9	30	40	40	Max	Ω
$I_{CH(OFF)}$	Switch OFF Leakage Current on Channel	$V_{IS} = V_{EE}$, $V_{OS} = V_{CC}$; or $V_{IS} = V_{CC}$, $V_{OS} = V_{EE}$	11	± 0.4	± 1	± 1	Max	μA
$I_{COM(OFF)}$	Switch OFF Leakage Current on Common	$V_{IS} = V_{EE}$, $V_{OS} = V_{CC}$; or $V_{IS} = V_{CC}$, $V_{OS} = V_{EE}$	11	± 0.4	± 4	± 4	Max	μA
$I_{(ON)}$	Switch ON Leakage Current	$V_{IS} = V_{EE}$ or V_{CC}	11	± 0.4	± 4	± 4	Max	μA
Dynamic Characteristics								
t_{PHL} , t_{PLH}	Switch IN to OUT time	$C_L = 50pF$	9	5			Typ	ns
t_{ON}	Switch turn-on time	$C_L = 50pF$	9	60			Max	ns
t_{OFF}	Switch turn-off time	$C_L = 50pF$	9	50			Max	ns
	OFF-Isolation	$f = 1MHz$, $R_L = 50\Omega$, $C_L = 10pF$	10	-70			Typ	dB
	Crosstalk	$f = 1MHz$, $R_L = 50\Omega$, $C_L = 10pF$	10	-70			Typ	dB
	Crosstalk in control	Between control and any switch; $R_L = 600\Omega$; $f = 1MHz$; E or Sn square wave between V_{CC} and GND	10	220			Typ	mV
BW	Bandwidth	$R_L = 50\Omega$	10	200			Typ	MHz
THD	Total Harmonic Distortion	$R_L = 10k\Omega$, $f = 1kHz$	10	0.03			Typ	%
Capacitance								
C_{IN}	Switch Input Capacitance		10	5			Typ	pF
C_{COM}	Common Output Capacitance		10	25			Typ	pF
C_{PD}	Power Dissipation Capacitance		10	50			Typ	pF

Dual Supply, $V_{CC} = 4.5$ to $5.5V$, $V_{EE} = -4.5$ to $5.5V$, $GND = 0V$, unless otherwise noted.

Symbol	Parameter	Conditions	V_{CC} $/V_{EE}(V)$	25°C	-40°C to 85°C	-40°C to 125°C	Limit	Unit
Power Supply								
I_{CC}	Quiescent Supply Current	$V_{IN} = V_{EE}$ or V_{CC}	5.5/-5.5	8	12	16	Max	μA
Digital Input								
V_{IH}	Input Voltage High				70%* V_{CC}	70%* V_{CC}	Min	V
V_{IL}	Input Voltage Low				30%* V_{CC}	30%* V_{CC}	Max	V
I_{IN}	Control Input Leakage	$V_{IN} = 0V$ or V_{CC}	5.5/-5.5	± 0.4	± 1	± 1	Max	μA
Analog Switch								
R_{ON}		$I_{OUT} = 1mA$, $V_{IS} = V_{EE}$ or V_{CC}	4.5/-4.5	50			Typ	Ω
R_{ON}		$I_{OUT} = 1mA$, $V_{IS} = V_{EE}$ or V_{CC}	4.5/-4.5	80	95	105	Max	Ω
ΔR_{ON}	On Resistance Match between Channels	$I_{OUT} = 1mA$, $V_{IS} = -3.5V$	4.5/-4.5	15	25	30	Max	Ω
$R_{FLAT(ON)}$	On Resistance Flatness	$I_{OUT} = 1mA$	4.5/-4.5	30	40	40	Max	Ω
$I_{CH(OFF)}$	Switch OFF Leakage Current on Channel	$V_{IS} = V_{EE}$, $V_{OS} = V_{CC}$; or $V_{IS} = V_{CC}$, $V_{OS} = V_{EE}$	5.5/-5.5	± 0.4	± 1	± 1	Max	μA
$I_{COM(OFF)}$	Switch OFF Leakage Current on Common	$V_{IS} = V_{EE}$, $V_{OS} = V_{CC}$; or $V_{IS} = V_{CC}$, $V_{OS} = V_{EE}$	5.5/-5.5	± 0.4	± 4	± 4	Max	μA
$I_{(ON)}$	Switch ON Leakage Current	$V_{IS} = V_{EE}$ or V_{CC}	5.5/-5.5	± 0.4	± 4	± 4	Max	μA
Dynamic Characteristics								
t_{PHL} , t_{PLH}	Switch IN to OUT time	$C_L = 50pF$	4.5/-4.5	5			Typ	ns
t_{ON}	Switch turn-on time	$C_L = 50pF$	4.5/-4.5	60			Max	ns
t_{OFF}	Switch turn-off time	$C_L = 50pF$	4.5/-4.5	50			Max	ns
	OFF-Isolation	$f = 1MHz$, $R_L = 50\Omega$, $C_L = 10pF$	5/-5	-70			Typ	dB
	Crosstalk	$f = 1MHz$, $R_L = 50\Omega$, $C_L = 10pF$	5/-5	-70			Typ	dB
	Crosstalk in control	Between control and any switch; $R_L = 600\Omega$; $f = 1MHz$; E or Sn square wave between V_{CC} and GND	5/-5	220			Typ	mV
BW	Bandwidth	$R_L = 50\Omega$	5/-5	200			Typ	MHz
THD	Total Harmonic Distortion	$R_L = 10k\Omega$, $f = 1kHz$	5/-5	0.03			Typ	%
Capacitance								
C_{IN}	Switch Input Capacitance		5/-5	5			Typ	pF
C_{COM}	Common Output Capacitance		5/-5	25			Typ	pF
C_{PD}	Power Dissipation Capacitance		5/-5	50			Typ	pF

Typical Performance Characteristics

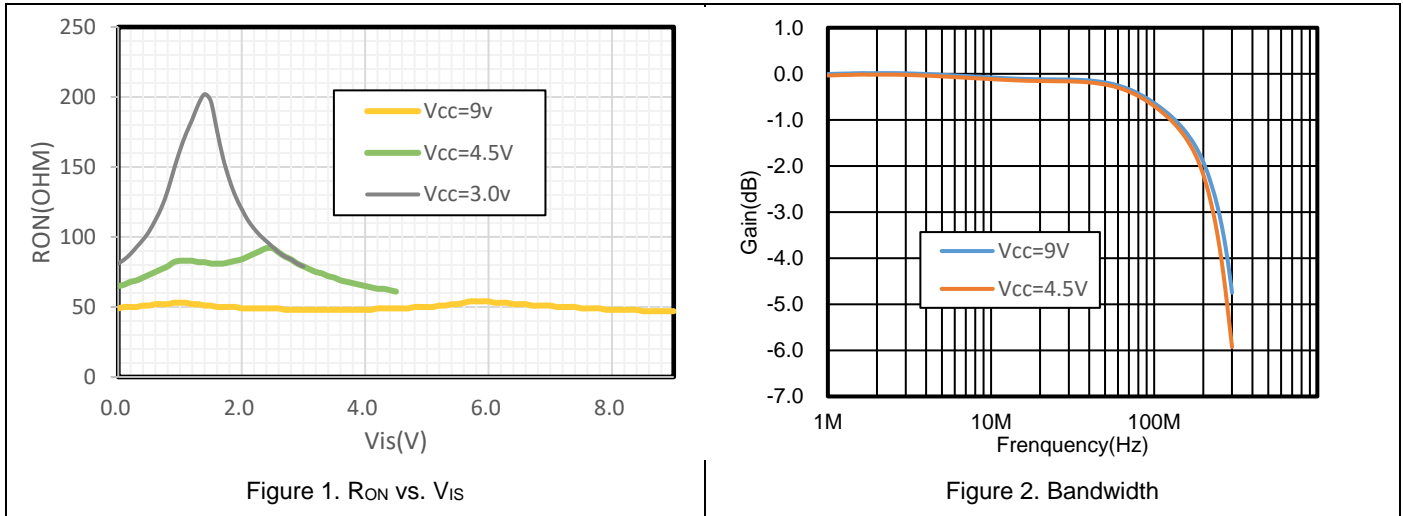

Test Circuit and Waveforms

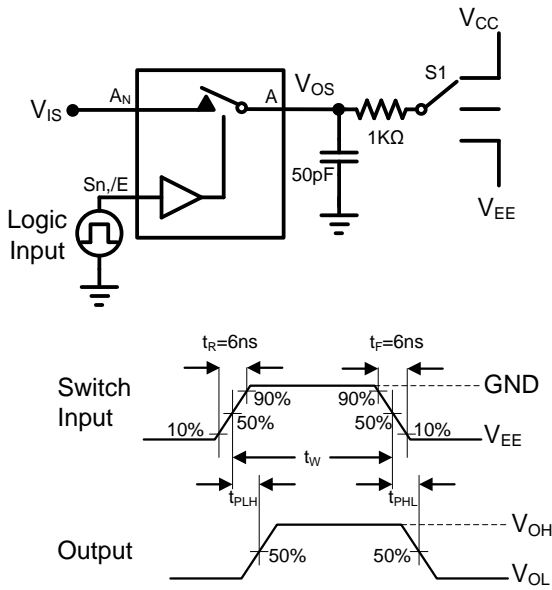

Parameter	Vis	S1 Position
t_{PHL}, t_{PLH}	Pulse	Open
t_{PZH}, t_{PHZ}	V_{CC}	V_{EE}
t_{PZL}, t_{PLZ}	V_{EE}	V_{CC}

$t_{ON}: t_{PZH}$ OR t_{PZL}
 $t_{OFF}: t_{PHZ}$ OR t_{PLZ}

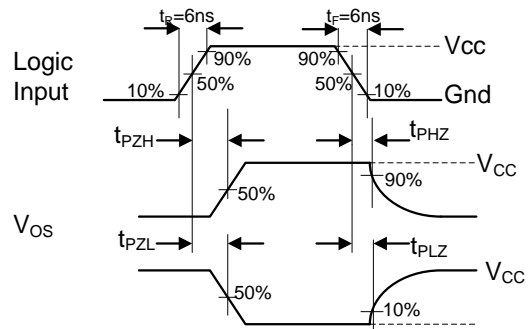

Figure 3 AC Test Circuit and Test Waveforms

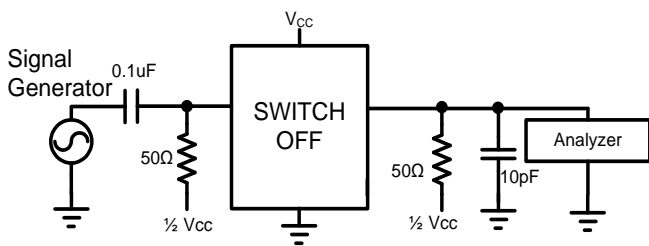

Figure 4 Off Isolation

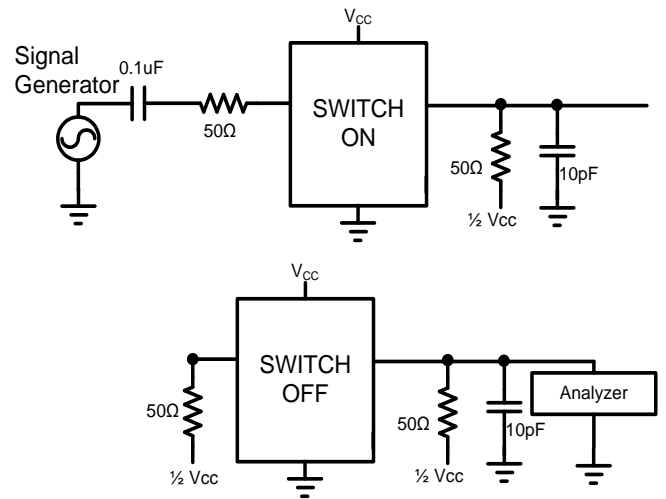
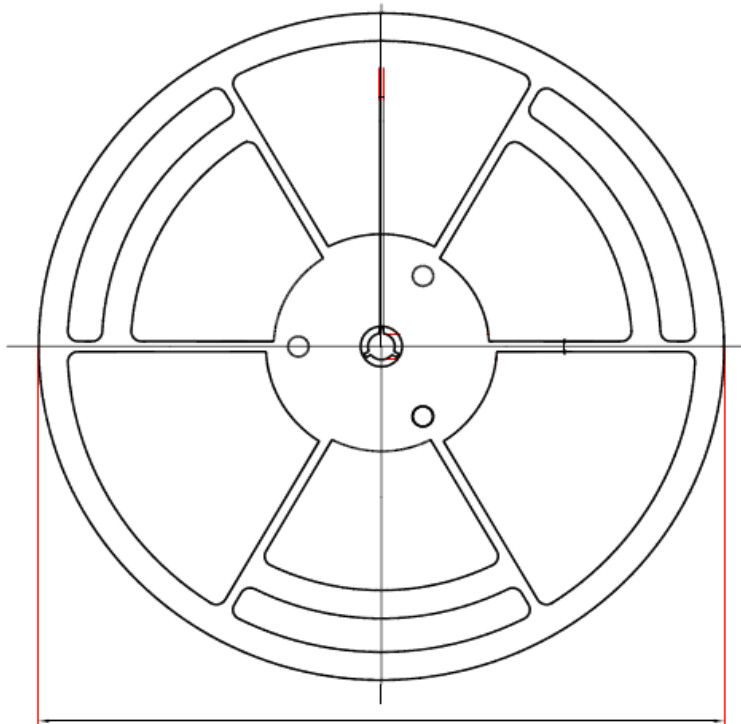

Figure 5 Crosstalk

Application Information

A 0.1- μ F bypass capacitor on V_{CC} and GND is recommended to prevent power disturbance, another 0.1- μ F bypass capacitor on V_{EE} and GND is also recommended if the V_{EE} is not connected to GND.

Tape and Reel Information



D1: Reel Diameter

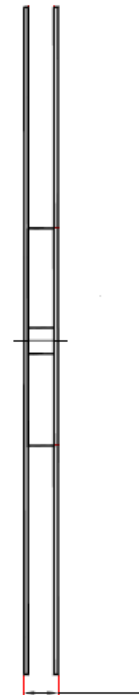

W1: Reel Width

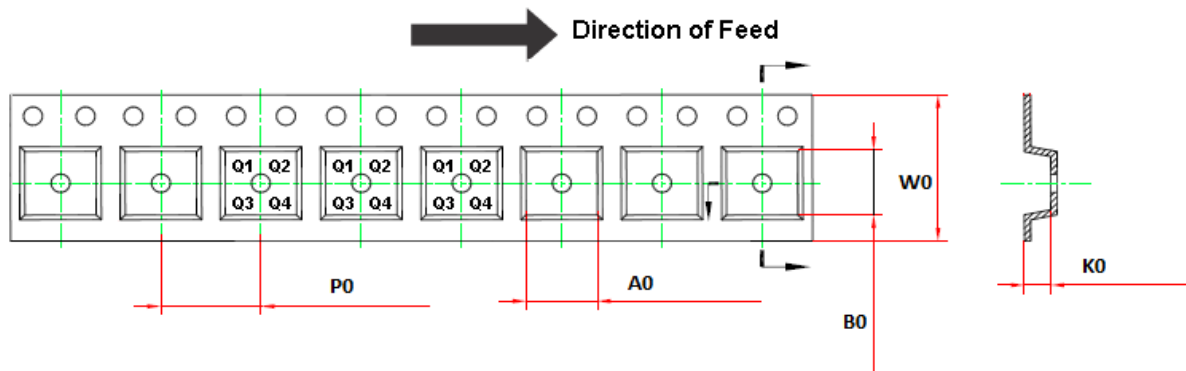

Order Number	Package	D1	W1	A0	B0	K0	P0	W0	Pin1 Quadrant
TPW4051-SR	SOIC-16	330	21.6	6.7±0.1	10.4±0.1	2.1±0.1	8.0±0.1	16.0±0.3	Q1
TPW4051-TR	TSSOP-16	330	17.6	6.8±0.1	5.4±0.1	1.3±0.1	8.0±0.1	12.0±0.1	Q1

Package Outline Dimensions

SOIC-16

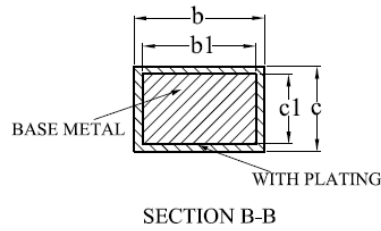
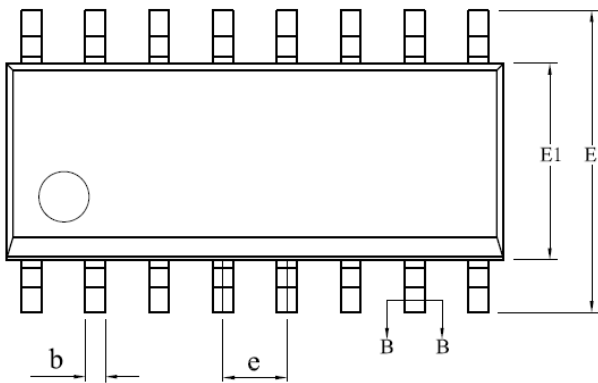
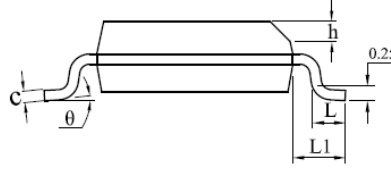
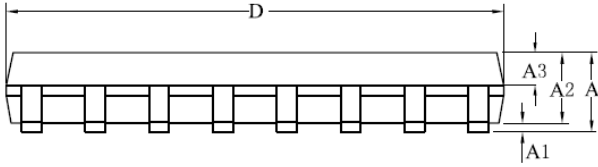

SYMBOL	MILLIMETER		
	MIN	NOM	MAX
A	—	—	1.75
A1	0.10	—	0.225
A2	1.30	1.40	1.50
A3	0.60	0.65	0.70
b	0.39	—	0.47
b1	0.38	0.41	0.44
c	0.20	—	0.24
c1	0.19	0.20	0.21
D	9.80	9.90	10.00
E	5.80	6.00	6.20
E1	3.80	3.90	4.00
e	1.27BSC		
h	0.25	—	0.50
L	0.50	—	0.80
L1	1.05REF		
theta	0	—	8°

TSSOP-16

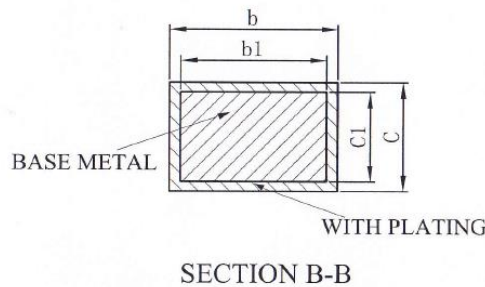
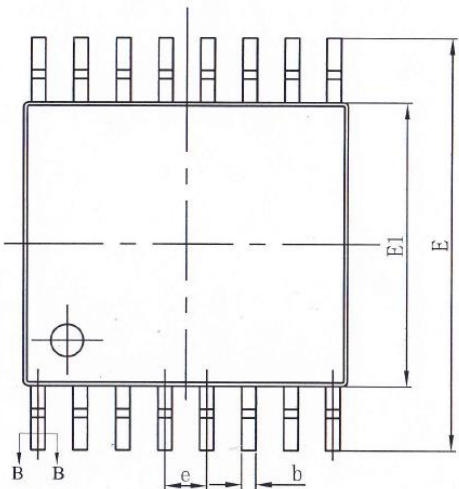
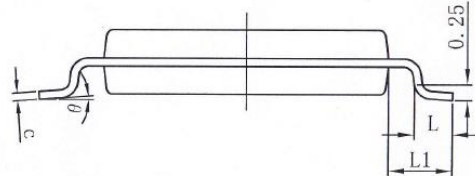
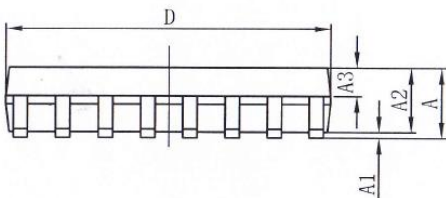

SYMBOL	MILLIMETER		
	MIN	NOM	MAX
A	—	—	1.20
A1	0.05	—	0.15
A2	0.90	1.00	1.05
A3	0.39	0.44	0.49
b	0.20	—	0.28
b1	0.19	0.22	0.25
c	0.13	—	0.17
c1	0.12	0.13	0.14
D	4.90	5.00	5.10
E	6.20	6.40	6.60
E1	4.30	4.40	4.50
e	0.65BSC		
L	0.45	0.60	0.75
L1	1.00BSC		
theta	0	—	8°

QFN-16

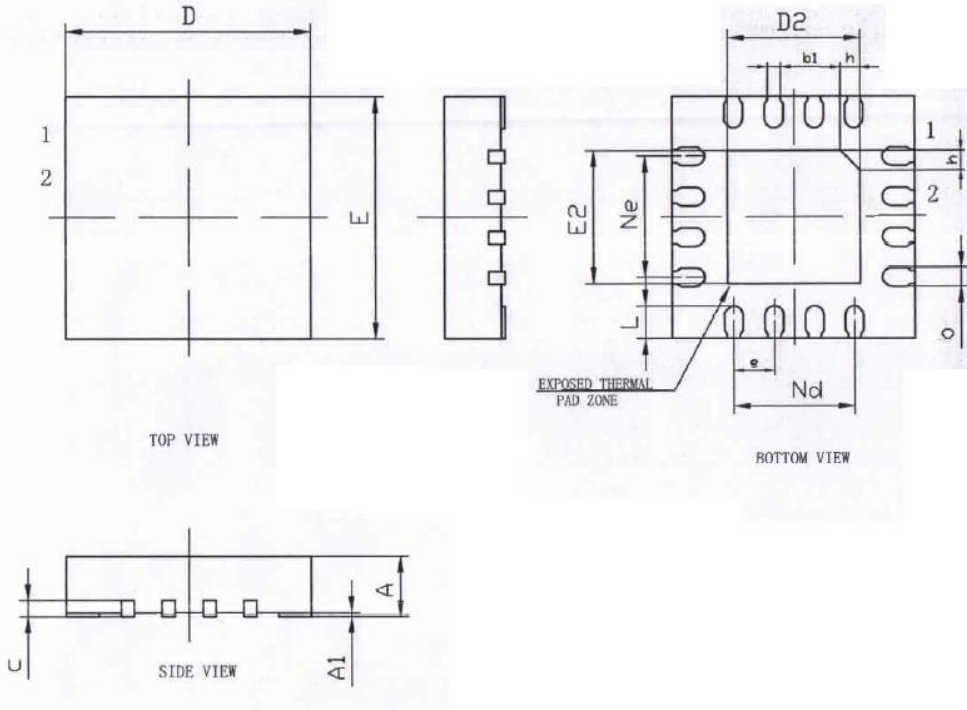

SYMBOL	MILLIMETER		
	MIN	NOM	MAX
A	0.70	0.75	0.80
	0.80	0.85	0.90
A1	0	0.02	0.05
b	0.18	0.25	0.30
b1	0.16REF		
c	0.18	0.20	0.25
D	2.90	3.00	3.10
D2	1.55	1.65	1.75
e	0.50BSC		
Ne	1.50BSC		
Nd	1.50BSC		
E	2.90	3.00	3.10
E2	1.55	1.65	1.75
L	0.35	0.40	0.45
h	0.20	0.25	0.30
L/载体尺寸 (mil)	75x75		

 ***3PEAK and the 3PEAK logo are registered trademarks of 3PEAK INCORPORATED. All other trademarks are the property of their respective owners.***
